

### Standard Features

1. Air Vent
2. Flanged Connections
3. Blow Down Valve
4. Skim Valve
5. Removable or Fixed Head
6. ASME Nameplate
7. Sight Glass (4)\*
8. Gauge Tap (2)\*

### \*Less Options:

- Minus Sight Glass x4
- Minus Gauge Tap x2

### MATERIALS OF CONSTRUCTION

Coalescing Media	Stainless Steel
Shell	Carbon Steel
Blow Down Valve	Bronze
Skim Valve	Bronze
Air Vent	Thrush Model 720

NOTE: IF REQUIRED, THE LOWER HEAD AND COALESCING MEDIA ARE REMOVABLE FOR CLEANING ON THE 'R' TYPE HEAD.

### MAXIMUM OPERATING CONDITIONS

Maximum Working Pressure (2"-12")	175 PSIG
Maximum Working Pressure (14"-24")	150 PSIG
Maximum Working Temperature	250° F

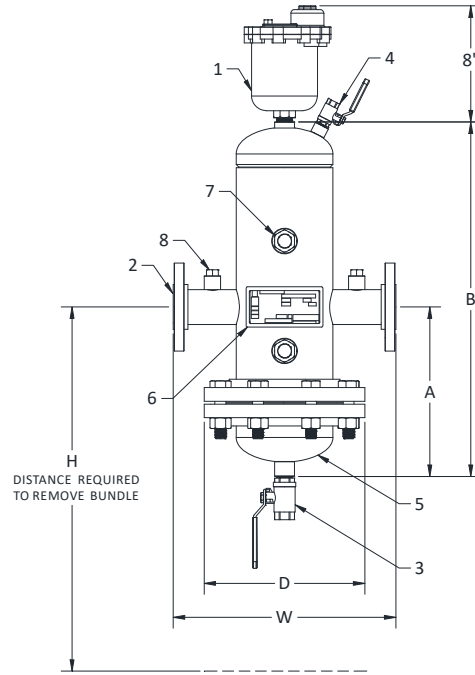

### Model Designation

**G** **B** **S** **R** - **040** - **W**

Grundfos

Separation Type

A=Air Only  
D=Dirt Only  
B=Both Air and Dirt  
4=Hydraulic Separator

Velocity

S=Standard Velocity  
H=High Velocity

Head Type

R=Removable  
F=Fixed

Connection Size

example: 025 = 2.5"  
or 100 = 10.0"

Options

W=with options  
X=less options\*

### DIMENSIONS

MODEL	CONNECTION SIZE**	(INCHES)					FLOW (GPM)	WEIGHT (LBS.) GBSR	WEIGHT (LBS.) GBSF
		A	B	D	W	H			
GBS*-020-*	2"	12.00	24.50	11.00	15.25	26.50	65	150	120
GBS*-025-*	2.5"	12.00	24.50	11.00	15.75	26.50	95	150	120
GBS*-030-*	3"	12.00	24.50	11.00	20.25	26.50	150	150	120
GBS*-040-*	4"	15.00	29.00	13.50	20.63	33.00	250	250	200
GBS*-050-*	5"	19.00	39.00	16.00	27.75	44.00	380	310	240
GBS*-060-*	6"	19.00	41.00	19.00	27.75	44.00	560	375	265
GBS*-080-*	8"	24.00	49.00	23.50	33.63	54.50	970	700	530
GBS*-100-*	10"	33.00	63.00	27.50	37.50	75.00	1510	1000	730
GBS*-120-*	12"	38.00	78.00	32.00	42.50	90.00	2130	1500	1110
GBS*-140-*	14"	43.00	94.00	35.00	45.00	104.00	2880	1950	1670
GBS*-160-*	16"	56.00	118.00	35.00	50.00	141.00	3760	2325	2045
GBS*-180-*	18"	55.00	121.00	41.62	56.00	138.00	4760	3250	2800
GBS*-200-*	20"	68.00	145.00	41.62	61.50	175.00	5880	4575	4125
GBS*-240-*	24"	73.00	150.00	55.00	72.00	175.00	8460	7250	6370

\*\*ANSI B16.5 150 PSI FLANGE

DESIGNED AND CONSTRUCTED PER ASME SECTION VIII, DIV. 1

Job Name \_\_\_\_\_  
Location \_\_\_\_\_  
Engineer \_\_\_\_\_  
Architect \_\_\_\_\_  
Sales Rep. \_\_\_\_\_  
Contractor \_\_\_\_\_

Model Number \_\_\_\_\_  
Temperature \_\_\_\_\_  
Capacity \_\_\_\_\_  
Liquid \_\_\_\_\_  
Notes \_\_\_\_\_