

---

# Compass R

## High-Efficiency Dry-Rotor Circulators

### PLV Replacement

---

## Installation and operating instructions

**File No:** 10.8971  
**Date:** APRIL 22, 2019  
**Supersedes:** 10.8971  
**Date:** MAY 10, 2018

---

---

—

—

—

—

# CONTENTS

<b>1.0</b>	Exploded assembly view	4
<b>2.0</b>	Replacement of PLV	5
<b>3.0</b>	Start-up	5
<b>3.1</b>	Before start- up	5
<b>3.2</b>	Venting the pump	5
<b>4.0</b>	Pump settings and pump performance	5
<b>4.1</b>	Pump performance curves	5

## 1.0 EXPLODED ASSEMBLY VIEW

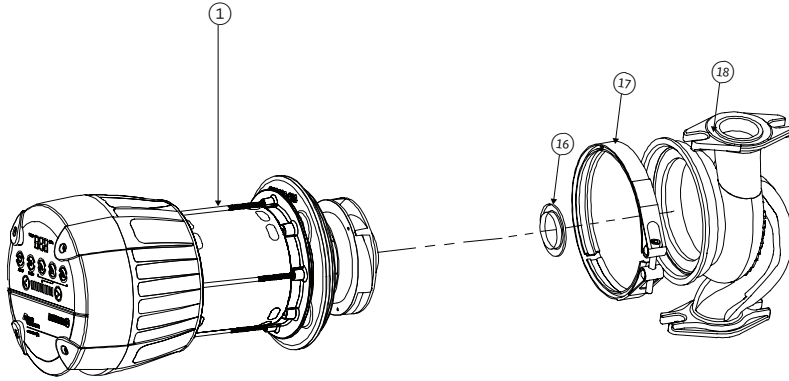

Pump Less Volute

INDEX	DESCRIPTION
1	Screw for controller housing M3×0.5×50
	Screw gasket
	Controller plate cover
	Screw from controller housing to driver housing M3×0.5×12
	Controller
	ECM motor
	Shaft key
	Water slinger
	Motor plate
	Plate bolts / washers
	O-ring
	Mechanical seal
	Impeller
	Impeller washer
	Impeller nut
16	Casing insert
17	Motor casing clasp
18	Casing

### Compass R Pump Less Volute

SR. NO	PART NUMBER	DESCRIPTION
1	119181-103	20-75 Pump Less Volute 115V
2	119182-103	20-75 Pump Less Volute 230V

The Compass R pump less volute includes a PLV and an o-ring

**NOTE:**

Repair part numbers can be found in the Circulator Parts List, **File#** 6010.201 (not all parts shown here are available for sale, this is to show an entire breakdown of the Compass R)

## 2.0 REPLACEMENT OF PLV

- 1 Turn off the pump leaving it installed in the line
- 2 Ensure electrical power is disconnected and locked out
- 3 Close the water supply at the points closest to the pump's inlet and outlet
- 4 For safety, allow water to cool to 100°F (40°C) before draining the system. It is best to leave the drain valve open while working on the system
- 5 Place a pan under the pump to collect the drain water
- 6 Bleed the water pressure from the pump
- 7 While holding the motor/pump assembly, loosen the V-Clamp
- 8 Remove the motor assembly straight out from the volute
- 9 Mount new O-Ring onto the new pump unit, apply O-Ring lubricant on adaptor
- 10 Install PLV into volute and tighten the V-Clamp

## 3.0 START-UP

### 3.1 BEFORE START- UP

Fill the system with liquid and properly vent the system before starting the pump. The required minimum inlet pressure in relation to liquid temperature must be available at the pump inlet .

### 3.2 VENTING THE PUMP

Even with system vented, air may be still be present in the pump. The air in the pump may cause noise but the noise should cease after a few minutes running.

The venting process can be shortened by setting the pump to run at max speed for a short period of time (60 seconds).

Once the pump is vented (the noise has ceased), set the pump mode according to the recommendations.

#### CAUTION



The pump must not run dry.

## 4.0 PUMP SETTINGS AND PUMP PERFORMANCE

### 4.1 PUMP PERFORMANCE CURVES

Compass R 20-75 performance curves—Auto, Fixed Head, Fixed Speed and Proportional Pressure Curves

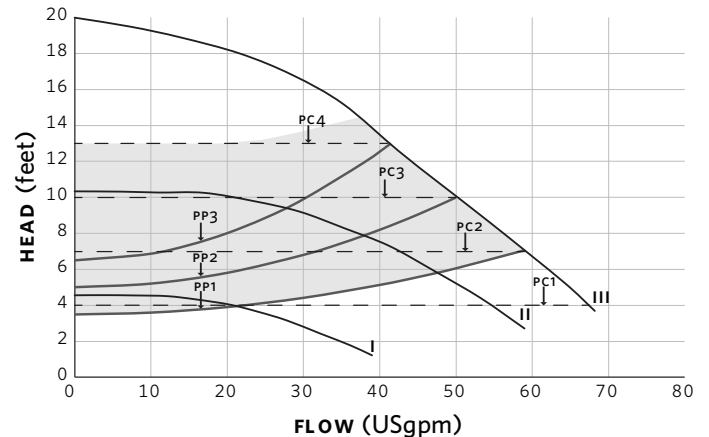

#### Manual control options

Fixed head curve - I, II, III

Fixed speed curve - PC1, PC2, PC3, PC4

Proportional pressure curve - PP1, PP2, PP3

AUTO - ■

Auto mode  
(Factory default)

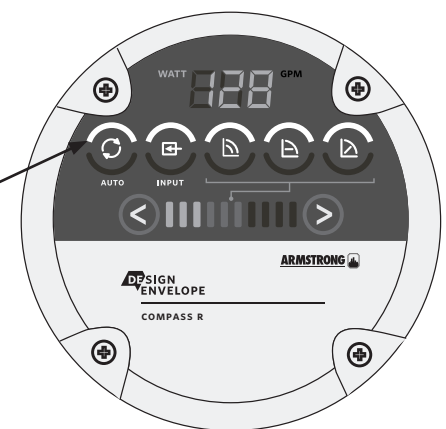

**TORONTO**

23 BERTRAND AVENUE  
TORONTO, ONTARIO  
CANADA  
M1L 2P3  
+1 416 755 2291

**BUFFALO**

93 EAST AVENUE  
NORTH TONAWANDA, NEW YORK  
U.S.A.  
14120-6594  
+1 716 693 8813

**BIRMINGHAM**

HEYWOOD WHARF, MUCKLOW HILL  
HALESOWEN, WEST MIDLANDS  
UNITED KINGDOM  
B62 8DJ  
+44 (0) 8444 145 145

**MANCHESTER**

WOLVERTON STREET  
MANCHESTER  
UNITED KINGDOM  
M11 2ET  
+44 (0) 8444 145 145

**BANGALORE**

#59, FIRST FLOOR, 3RD MAIN  
MARGOSA ROAD, MALLESWARAM  
BANGALORE, INDIA  
560 003  
+91 (0) 80 4906 3555

**SHANGHAI**

UNIT 903, 888 NORTH SICHUAN RD  
HONGKOU DISTRICT  
SHANGHAI, CHINA  
200085  
+86 (0)21 5237 0909

**SÃO PAULO**

RUA JOSÉ SEMIÃO RODRIGUES AGOSTINHO,  
1370 GALPÃO 6  
EMBU DAS ARTES  
SAO PAULO, BRAZIL  
+55 11 4785 1330

ARMSTRONG FLUID TECHNOLOGY  
ESTABLISHED 1934

ARMSTRONGFLUIDTECHNOLOGY.COM

**MAKING  
ENERGY  
MAKE  
SENSE™**