

Series e-82SC

Table of Contents

| | |
|--|-----------|
| 1 Introduction and Safety | 3 |
| 1.1 Introduction..... | 3 |
| 1.2 Safety..... | 3 |
| 1.2.1 Safety terminology and symbols..... | 3 |
| 1.2.2 Safety instruction decals..... | 4 |
| 1.3 User safety..... | 5 |
| 1.3.1 Wash the skin and eyes..... | 6 |
| 1.4 Protecting the environment..... | 6 |
| | |
| 2 Transportation and Storage | 7 |
| 2.1 Examine the delivery..... | 7 |
| 2.1.1 Examine the package..... | 7 |
| 2.1.2 Examine the unit..... | 7 |
| 2.2 Pump lifting..... | 7 |
| 2.3 Long-term storage..... | 8 |
| | |
| 3 Product Description | 9 |
| 3.1 General description..... | 9 |
| 3.2 Operational specifications..... | 10 |
| | |
| 4 Installation | 11 |
| 4.1 Preinstallation..... | 11 |
| 4.1.1 Pump mounting guidelines..... | 11 |
| 4.1.2 Pump location guidelines..... | 11 |
| 4.1.3 Piping checklist..... | 12 |
| 4.2 Typical pump installation..... | 13 |
| 4.3 Typical system installation..... | 15 |
| | |
| 5 Commissioning, Startup, Operation, and Shutdown | 16 |
| 5.1 Preparation for startup..... | 16 |
| 5.1.1 Check the rotation..... | 16 |
| 5.2 Prime the pump..... | 17 |
| 5.3 Start the pump..... | 17 |
| 5.4 Pump operation precautions..... | 18 |
| 5.5 Shut down the pump..... | 18 |
| 5.6 Vibration..... | 18 |
| | |
| 6 Maintenance | 19 |
| 6.1 Standby operation..... | 19 |
| 6.2 Flapper valve..... | 19 |
| 6.3 Lubrication..... | 19 |
| 6.4 Disassembly..... | 19 |
| 6.4.1 Disassembly precautions..... | 20 |
| 6.4.2 Drain the pump..... | 20 |
| 6.4.3 Impeller trimming guidelines..... | 20 |
| 6.5 Pre-assembly inspections..... | 20 |
| 6.5.1 Replacement guidelines..... | 21 |
| 6.5.2 Shaft inspection..... | 21 |
| 6.6 Reassembly..... | 21 |
| 6.6.1 Replace the seal..... | 21 |

| | | |
|----------|--|-----------|
| 6.6.2 | Motor collar ring setting..... | 23 |
| 6.6.3 | Assemble the coupler..... | 24 |
| 6.6.4 | Assemble the flapper valve..... | 26 |
| 6.6.5 | Blind flange use..... | 26 |
| 6.6.6 | Screw torque values..... | 27 |
| 6.6.7 | Dealer servicing | 27 |
| 7 | Troubleshooting..... | 28 |
| 7.1 | Precautions..... | 28 |
| 7.2 | The pump unit is turned on but does not work..... | 28 |
| 7.3 | The differential protection device (RCD) is activated..... | 28 |
| 7.4 | The thermal overload protection of the motor is triggered when the pump unit starts..... | 28 |
| 7.5 | The thermal overload protection of the motor is triggered occasionally, or after the pump unit has been running for a few minutes..... | 29 |
| 7.6 | The pump unit runs but delivers too little or no liquid..... | 29 |
| 7.7 | The pump unit turns the other way when turned off..... | 29 |
| 7.8 | The pump unit produces excessive noise and/or vibrations..... | 29 |
| 7.9 | The pump starts up too frequently (automatic start/stop)..... | 30 |
| 7.10 | The pump unit never stops (automatic start/stop)..... | 30 |
| 7.11 | The mechanical seal is leaking..... | 30 |
| 7.12 | The motor becomes excessively hot..... | 31 |
| 7.13 | The frequency converter (if present) is in error mode or turned off..... | 31 |
| 8 | Product Warranty..... | 32 |

1 Introduction and Safety

1.1 Introduction

Purpose of this manual

The purpose of this manual is to provide necessary information for:

- Installation
- Operation
- Maintenance



CAUTION:

Read this manual carefully before installing and using the product. Improper use of the product can cause personal injury and damage to property, and may void the warranty.

NOTICE:

Save this manual for future reference, and keep it readily available at the location of the unit.

Requesting other information

Special versions can be supplied with supplementary instruction leaflets. See the sales contract for any modifications or special version characteristics. For instructions, situations, or events that are not considered in this manual or in the sales documents, please contact the nearest Xylem representative.

Always specify the exact product type and identification code when requesting technical information or spare parts.

1.2 Safety



WARNING:

- The operator must be aware of safety precautions to prevent physical injury.
 - Operating, installing, or maintaining the unit in any way that is not covered in this manual could cause death, serious personal injury, or damage to the equipment. This includes any modification to the equipment or use of parts not provided by Xylem. If there is a question regarding the intended use of the equipment, please contact a Xylem representative before proceeding.
 - Do not change the service application without the approval of an authorized Xylem representative.
-



CAUTION:

You must observe the instructions contained in this manual. Failure to do so could result in physical injury, damage, or delays.



1.2.1 Safety terminology and symbols

About safety messages

It is extremely important that you read, understand, and follow the safety messages and regulations carefully before handling the product. They are published to help prevent these hazards:



- Personal accidents and health problems
- Damage to the product and its surroundings
- Product malfunction

Hazard levels

| Hazard level | Indication |
|---|--|
|  DANGER: | A hazardous situation which, if not avoided, will result in death or serious injury |
|  WARNING: | A hazardous situation which, if not avoided, could result in death or serious injury |
|  CAUTION: | A hazardous situation which, if not avoided, could result in minor or moderate injury |
| NOTICE: | Notices are used when there is a risk of equipment damage or decreased performance, but not personal injury. |

Special symbols

Some hazard categories have specific symbols, as shown in the following table.

| Electrical hazard | Magnetic fields hazard |
|--|---|
|  Electrical Hazard: |  CAUTION: |

1.2.2 Safety instruction decals

Alert symbol

| | |
|---|--|
|  | <p>This safety alert symbol is used in manuals and on the safety instruction decals on the pump to draw attention to safety-related instructions.</p> <p>When used, the safety alert symbol means that failure to follow the instructions may result in a safety hazard.</p> |
|---|--|

Decals

Make sure your pump has these safety instruction decals and that they are located as this figure shows. If the decals are missing or illegible, contact your local sales and service representative for a replacement.

All series e-82SC Pumps

All series e-82SC with optional ITSC/IT

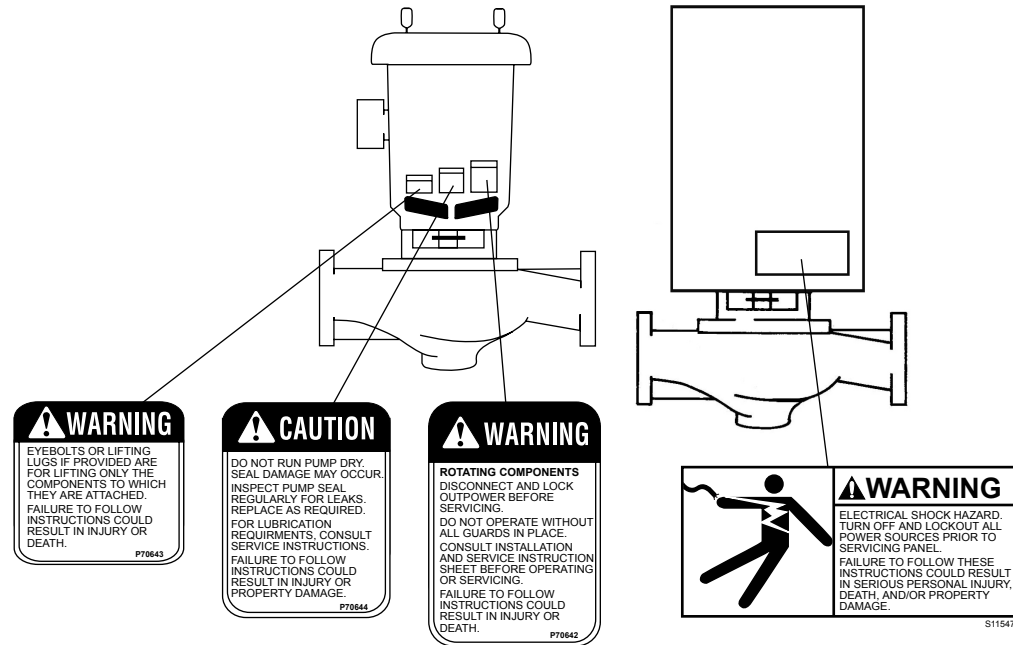

Make sure that all safety instruction decals are always clearly visible and readable.

1.3 User safety

General safety rules

These safety rules apply:

- Always keep the work area clean.
- Pay attention to the risks presented by gas and vapors in the work area.
- Avoid all electrical dangers. Pay attention to the risks of electric shock or arc flash hazards.
- Always bear in mind the risk of drowning, electrical accidents, and burn injuries.

Safety equipment

Use safety equipment according to the company regulations. Use this safety equipment within the work area:

- Hard hat
- Safety goggles, preferably with side shields
- Protective shoes
- Protective gloves
- Gas mask
- Hearing protection
- First-aid kit
- Safety devices

NOTICE:

Never operate a unit unless safety devices are installed. Also see specific information about safety devices in other chapters of this manual.

Electrical connections

Electrical connections must be made by certified electricians in compliance with all international, national, state, and local regulations. For more information about requirements, see sections dealing specifically with electrical connections.

Precautions before work

Observe these safety precautions before you work with the product or are in connection with the product:

- Provide a suitable barrier around the work area, for example, a guard rail.
- Make sure that all safety guards are in place and secure.
- Make sure that you have a clear path of retreat.
- Make sure that the product cannot roll or fall over and injure people or damage property.
- Make sure that the lifting equipment is in good condition.
- Use a lifting harness, a safety line, and a breathing device as required.
- Allow all system and pump components to cool before you handle them.
- Make sure that the product has been thoroughly cleaned.
- Disconnect and lock out power before you service the pump.
- Check the explosion risk before you weld or use electric hand tools.

1.3.1 Wash the skin and eyes

Follow these procedures for chemicals or hazardous fluids that have come into contact with your eyes or your skin:

| Condition | Action |
|---------------------------------------|--|
| Chemicals or hazardous fluids in eyes | <ol style="list-style-type: none"> 1. Hold your eyelids apart forcibly with your fingers. 2. Rinse the eyes with eyewash or running water for at least 15 minutes. 3. Seek medical attention. |
| Chemicals or hazardous fluids on skin | <ol style="list-style-type: none"> 1. Remove contaminated clothing. 2. Wash the skin with soap and water for at least 1 minute. 3. Seek medical attention, if necessary. |

1.4 Protecting the environment

Emissions and waste disposal

Observe the local regulations and codes regarding:

- Reporting of emissions to the appropriate authorities
- Sorting, recycling and disposal of solid or liquid waste
- Clean-up of spills

Exceptional sites



CAUTION: Radiation Hazard

Do NOT send the product to Xylem if it has been exposed to nuclear radiation, unless Xylem has been informed and appropriate actions have been agreed upon.

Recycling guidelines

Always follow local laws and regulations regarding recycling.

2 Transportation and Storage

2.1 Examine the delivery

2.1.1 Examine the package

1. Examine the package for damaged or missing items upon delivery.
2. Record any damaged or missing items on the receipt and freight bill.
3. If anything is out of order, then file a claim with the shipping company.
If the product has been picked up at a distributor, make a claim directly to the distributor.

2.1.2 Examine the unit

1. Remove packing materials from the product.
Dispose of all packing materials in accordance with local regulations.
2. To determine whether any parts have been damaged or are missing, examine the product.
3. If applicable, unfasten the product by removing any screws, bolts, or straps.
Use care around nails and straps.
4. If there is any issue, then contact a sales representative.

2.2 Pump lifting



WARNING:

- Assembled units and their components are heavy. Failure to properly lift and support this equipment can result in serious physical injury and/or equipment damage. Lift equipment only at the specifically identified lifting points. Lifting devices such as eyebolts, slings, and spreaders must be rated, selected, and used for the entire load being lifted.
- Crush hazard. The unit and the components can be heavy. Use proper lifting methods and wear steel-toed shoes at all times.

In order to lift the entire pump, use slings placed around the unit as shown.

Series e-82SC

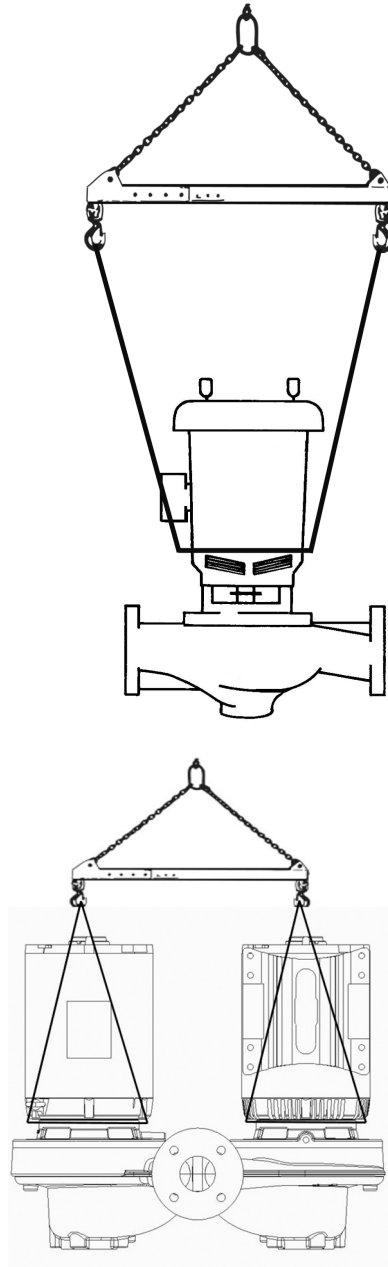

Series e-82SC with optional ITSC/IT

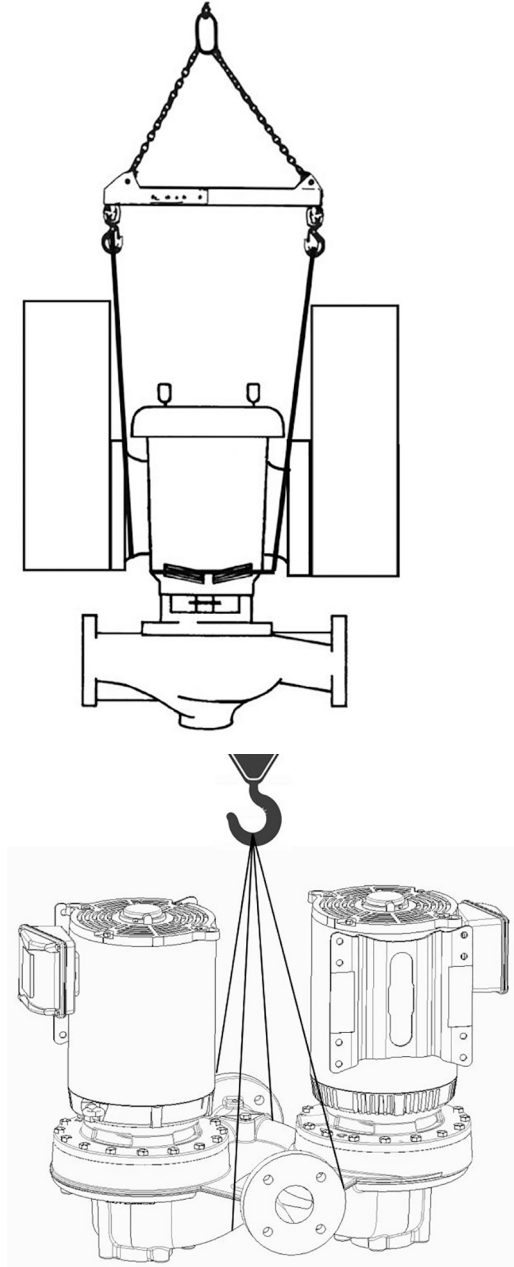

Figure 1: Proper lifting method

2.3 Long-term storage

If the unit is stored for more than 6 months, these requirements apply:

- Store in a covered and dry location.
- Store the unit free from heat, dirt, and vibrations.
- Rotate the shaft by hand several times at least every three months.

Treat bearing and machined surfaces so that they are well preserved. Refer to the drive unit and coupling manufacturers for their long-term storage procedures.

For questions about possible long-term storage treatment services, please contact your local sales and service representative.

3 Product Description

3.1 General description

The pump is a split coupled pump. These features make the pump easy to install, operate, and service:

- High efficiency
- Rugged stainless steel-fitted construction
- Vertical in-line mounting

Mechanical seal options

The pump has two options for the mechanical seal.

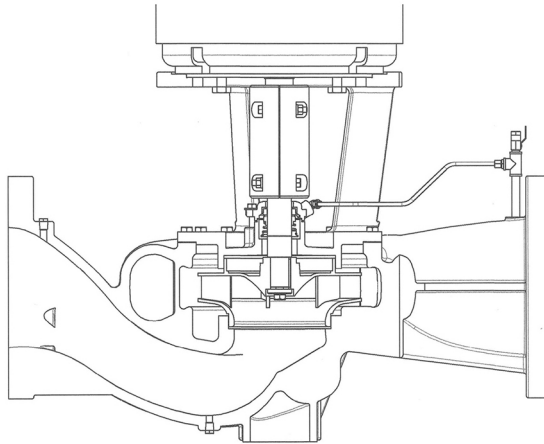

Figure 2: Inside mechanical seal

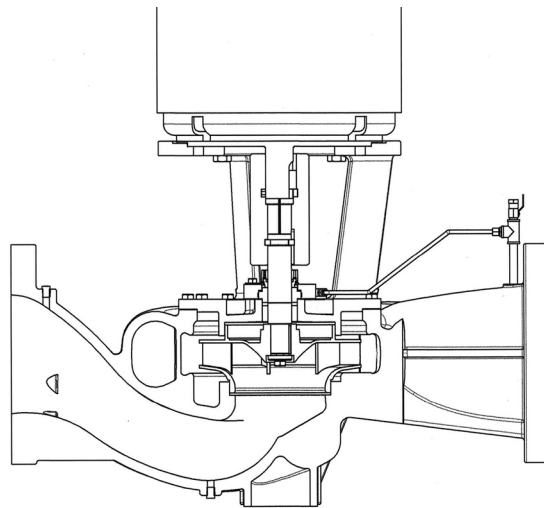

Figure 3: Outside mechanical seal

Intended applications



WARNING:

This product can expose you to chemicals including Lead, which is known to the State of California to cause cancer and birth defects or other reproductive harm. For more information go to: www.P65Warnings.ca.gov.

NOTICE:

- This product is not intended for potable water applications.
- This product is non-submersible. For indoor use only.
- This product has not been investigated, nor is it intended for, use in swimming pools and marine areas.

The pump is intended for use with these pumped fluids:

- Unheated domestic and fresh water
- Boiler feed water
- Condensate
- Hydronic cooling or heating
- Benign liquids
- Pressure boosting
- General liquid transfer

Rotation

Pump rotation is clockwise when viewed from the back of the motor. An arrow is also located on the pump to show the direction of rotation.

3.2 Operational specifications

| Seal type/Parameter | Standard seal, EPR/ Carbon/Tungsten Carbide | Optional seal, FKM/ Carbon/Ceramic | Optional seal, EPR/ Silicon Carbide/ Silicon Carbide | Optional seal, EPR/ Carbon/Tungsten Carbide |
|--|---|---------------------------------------|--|---|
| Operating temperature range, °F (°C) | -20 to 250 (-29 to 121) | -10 to 225 (-23 to 107) | -20 to 250 (-29 to 121) | -20 to 250 (-29 to 121) |
| pH range limits | 7.0 to 11.0 | 7.0 to 9.0 | 7.0 to 12.5 | 7.0 to 9.0 |
| Resistance to dissolved solids | Low-Medium | Low | Medium-High | Low-Medium |
| Maximum glycol/ water concentration | 50/50% | 50/50% | 60/40% | 50/50% |

Table notes

1. An external flush is required on low pressure systems that contain a high concentration of abrasives.
2. For operating temperatures above 250°F, a cooled flush is required and is recommended for temperatures above 225°F for optimum seal life. On closed systems, cooling is accomplished by inserting a small heat exchanger in the flush line to cool the seal flushing fluid.
3. Flush-line filters and sediment separators are available on request.

4 Installation

4.1 Preinstallation

Precautions



WARNING:

- When installing in a potentially explosive environment, make sure that the motor is properly certified.
 - You must ground (earth) all electrical equipment. This applies to the pump equipment, the driver, and any monitoring equipment. Test the ground (earth) lead to verify that it is connected correctly.
 - Motors without built-in protection must be provided with contactors and thermal overload protection for single-phase motors, or starters with heaters for three-phase motors. (See the nameplate on the drive unit to select properly-sized overloads.)
-

NOTICE:

Supervision by an authorized Xylem representative is recommended to ensure proper installation. Failure to do so may result in equipment damage or decreased performance.

Evaluate the installation in order to determine that the Net Positive Suction Head Available (NPSH_A) meets or exceeds the Net Positive Suction Head Required (NPSH_R), as stated by the pump performance curve.

4.1.1 Pump mounting guidelines

Series e-82SC pumps can only be mounted with the motor shaft vertical (motor shaft down).

The optional Integrated Technologic with Sensorless Control (ITSC) or Integrated Technologic (IT) can be oriented to different positions relative to the pump nozzles. This can be easily changed during pump installation by removing the motor mounting capscrews, raising the motor assembly slightly, 0.015 to 0.030" (if needed), and rotating the motor assembly around the pump centerline. Raising the motor assembly more than 0.030" could damage the mechanical seal. Replace the motor capscrews when the preferred position is determined.



CAUTION:

The pump and motor assembly must be properly supported during this procedure to prevent the pump unit or motor assembly from falling. Failure to properly support the pump and motor assembly could result in personal injury and or property damage.

4.1.2 Pump location guidelines



WARNING:

Assembled units and their components are heavy. Failure to properly lift and support this equipment can result in serious physical injury and/or equipment damage. Lift equipment only at the specifically identified lifting points. Lifting devices such as eyebolts, slings, and spreaders must be rated, selected, and used for the entire load being lifted.

| Guideline | Explanation/comment |
|---|---|
| Keep the pump as close to the liquid source as practically possible. | This minimizes the friction loss and keeps the suction piping as short as possible. |
| If the pump is not on a closed system, locate the pump so that the fewest number of bends or elbows in the suction pipe are needed. | |

| Guideline | Explanation/comment |
|---|--|
| Make sure that the space around the pump is sufficient. | This facilitates ventilation, inspection, maintenance, and service. |
| If you require lifting equipment such as a hoist or tackle, make sure that there is enough space above the pump. For pumps with the optional ITSC/IT installed, be careful not to damage the ITSC/IT during lifting. Do not wrap the sling around the ITSC/IT. | This makes it easier to properly use the lifting equipment and safely remove and relocate the components to a safe location. |
| Protect the unit from weather and water damage due to rain, flooding, and freezing temperatures. | This is applicable if nothing else is specified. |
| Do not install and operate the equipment in closed systems unless the system is constructed with properly-sized safety devices and control devices. | Acceptable devices: <ul style="list-style-type: none"> • Pressure relief valves • Expansion tanks • Pressure controls • Temperature controls • Flow controls If the system does not include these devices, consult the engineer or architect in charge before you operate the pump. |
| Take into consideration the occurrence of unwanted noise and vibration. | The best pump location for noise and vibration absorption is on a concrete floor with subsoil underneath. |
| If the pump location is overhead, undertake special precautions to reduce possible noise transmission. | Consider a consultation with a noise specialist. |
| When possible, locate the pump below the fluid level. | This facilitates priming, ensures a steady flow of liquid, and provides a positive suction head on the pump. |

4.1.3 Piping checklist



WARNING:

- The heating of water and other fluids causes volumetric expansion. The associated forces can cause the failure of system components and the release of high-temperature fluids. In order to prevent this, install properly sized and located compression tanks and pressure-relief valves. Failure to follow these instructions can result in serious personal injury or death, or property damage.
- Avoid serious personal injury and property damage. Make sure that the flange bolts are adequately torqued.

NOTICE:

Never force piping to make a connection with a pump.

| Check | Explanation/comment | Checked |
|--|--|---------|
| Check that a section of straight pipe, with a length that is five times its diameter, is installed between the suction side of the pump and the first elbow, or that a B&G Suction Diffuser Plus is installed. | This reduces suction turbulence by straightening the flow of liquid before it enters the pump. | |
| Check that the suction and discharge pipes are supported independently by use of pipe hangers near the pump . | This eliminates pipe strain on the pump . | |
| Check that there is a strong, rigid support for the suction and discharge lines. | As a rule, ordinary wire or band hangers are not adequate to maintain proper alignment. | |
| For pumps with flanges, check that the bolt holes in the pump flanges match the bolt holes in the pipe flanges. | – | |

| Check | Explanation/comment | Checked |
|--|--|---------|
| Check that the suction or discharge lines are not forced into position. | Coupling and bearing wear will result if suction or discharge lines are forced into position. The code for Pressure Piping (A.S.A.B. 31.1) lists many types of supports available for various applications. | |
| Check that fittings for absorbing expansion are installed in the system when considerable temperature changes are expected. | This helps to avoid strain on the pump. | |
| Check that you have a foot valve of equal or greater area than the pump suction piping when you use in an open system with a suction lift. | Prevent clogging by using a strainer at the suction inlet next to the foot valve. Make sure that the strainer has an area three times that of the suction pipe with a mesh hole diameter of no less than 0.25 in. (0.64 cm). | |
| Check that flexible piping is used on both the suction and discharge sides of the pump when you use an isolation base. | – | |
| Check that a B&G Triple Duty® valve is installed in the discharge line. | This valve serves as a check valve that protects the pump from water hammer, and serves as an isolation valve for servicing and for throttling. | |
| Check that the pipeline has isolation valves around the pump and has a drain valve in the suction pipe. | – | |

4.2 Typical pump installation

Various installation arrangements can be used as described below.

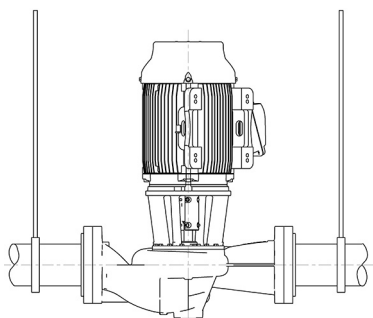

Figure 4

Series e-82SC pumps with up to 3 inch nozzles and up to 215 NEMA frame motors can be installed directly in the piping with pipe hangers adequate to carry the loads from the pump and piping. See [Figure 4](#): on page 13.

Please consult a structural engineer with questions or to validate your pump installation with plumbing configuration.

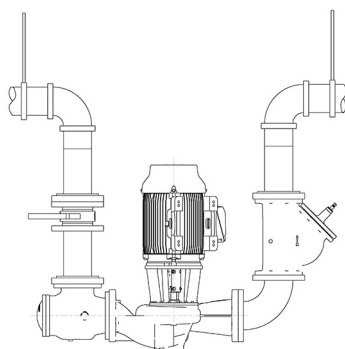

Figure 5

In many installations, the piping is installed near the ceiling with the pump located close to the floor for ease of maintenance. Pumps with up to 3 inch nozzles and up to 215 NEMA frame motors can be installed in this configuration with pipe hangers adequate to carry the loads from the pump, piping and piping accessories. Larger pumps can be installed in this configuration but require either the optional B&G Flange Supports or a floor support under the discharge elbow and an adjustable support leg under the B&G Suction Diffuser Plus. See [Figure 5](#): on page 13

Please consult a structural engineer with questions or to validate your pump installation with plumbing configuration.

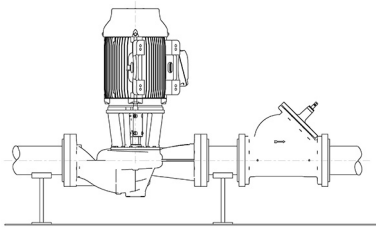

Figure 6

Pumps can be installed in the piping with floor mounted saddles adequate to carry the loads from the pump and piping. See [Figure 6](#): on page 14

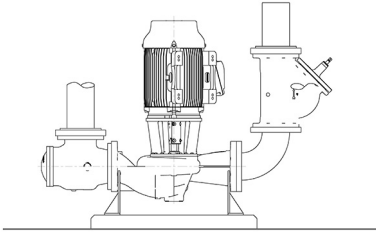

Figure 7

Optional B&G Flange Supports can be used when rigid pump support to the floor or isolation base is required. The supports are installed on the back side of the pump flanges and have tapped holes to accept the flange bolting and have mounting holes in their bases for anchor bolts. Pipe supports (not shown) are required such that the pump flanges are not supporting the piping. See [Figure 7](#): on page 14

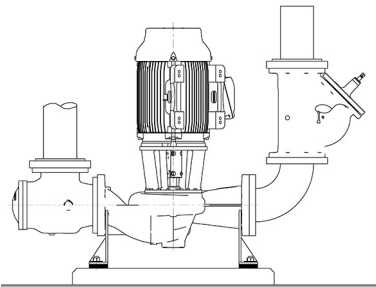

Figure 8

Alternately with the optional B&G Flange Supports, isolation pads can be used between the support and the floor. See [Figure 8](#): on page 14

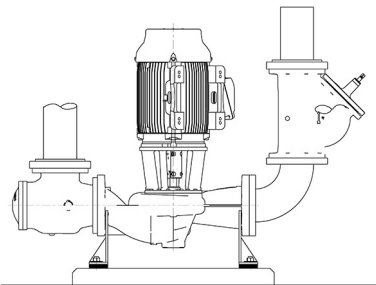

Figure 9

For seismic region installation, use seismically-rated isolation pads between the flange supports and the concrete foundation. See [Figure 9](#): on page 14

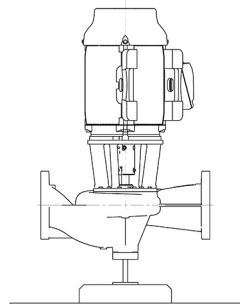
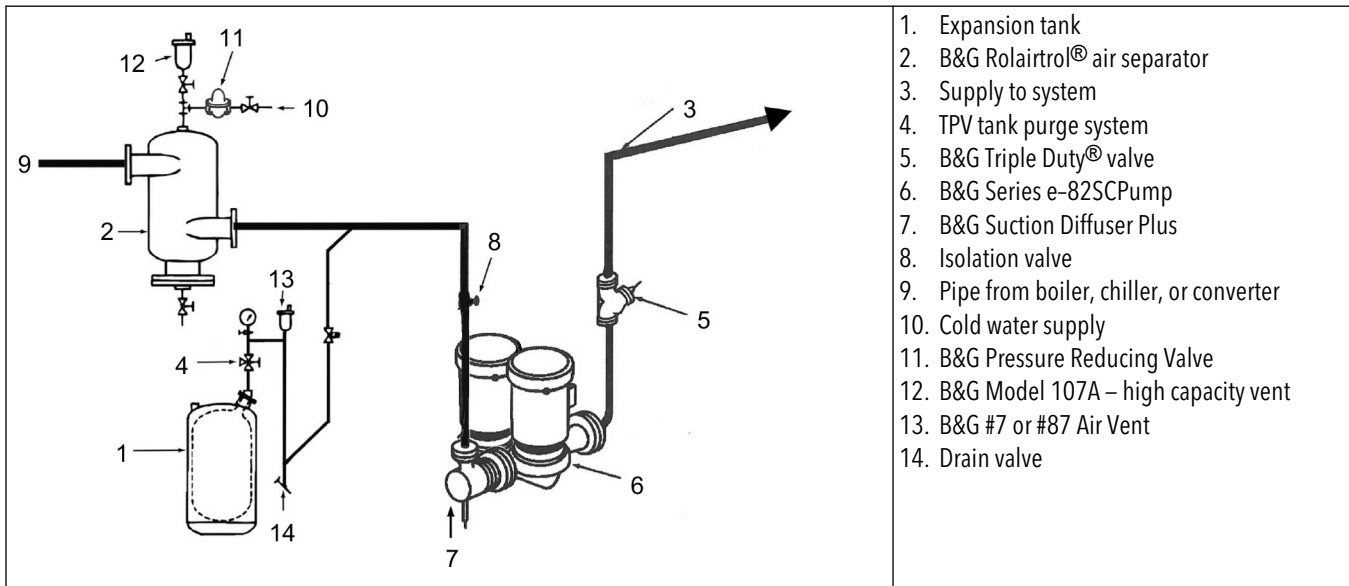

Figure 10

e-82SC pumps have a four bolt circle on the bottom of the volute to accept an ANSI/ASME flange that can be used with a connected pipe as a temporary pump support while the permanent pump piping or pump supports are being fitted to the pump. This support can only be used to handle the pump weight as it is not suitable to resist loads in other directions. See [Figure 10](#): on page 14

For installations in grooved piping systems when the pump is supported by the piping, flange locking type grooved piping connections are required to prevent the pump from rotating in the piping.

4.3 Typical system installation



Check that the control and safety devices have these characteristics:

- Properly sized for their purpose
- Placed correctly in the system before putting the system into operation

5 Commissioning, Startup, Operation, and Shutdown

5.1 Preparation for startup



WARNING:

- Failure to follow these precautions before you start the unit will lead to serious personal injury and equipment failure.
 - Do not operate the pump below the minimum rated flows or with the suction or discharge valves closed. These conditions can create an explosive hazard due to vaporization of pumped fluid and can quickly lead to pump failure and physical injury.
 - If the pump, motor, or piping operate at extremely high or low temperatures, then guarding or insulation is required. Failure to follow these instructions can result in serious personal injury or death, and property damage.
 - Always disconnect and lock out power to the driver before you perform any installation or maintenance tasks. Failure to disconnect and lock out driver power will result in serious physical injury.
 - Operating the pump in reverse rotation can result in the contact of metal parts, heat generation, and breach of containment.
-

NOTICE:

- Verify the driver settings before you start any pump.
 - Make sure that the warm-up rate does not exceed 2.5°F (1.4°C) per minute.
-

You must follow these precautions before you start the pump:

- Flush and clear the system thoroughly to remove dirt or debris in the pipe system in order to prevent premature failure at initial startup.
- Bring variable-speed drivers to the rated speed as quickly as possible.
- Run a new or rebuilt pump at a speed that provides enough flow to flush and cool the close-running surfaces of the stuffing-box bushing.
- If temperatures of the pumped fluid will exceed 200°F (93°C), then warm up the pump prior to operation. Circulate a small amount of fluid through the pump until the casing temperature is within 100°F (38°C) of the fluid temperature.

At initial startup, do not adjust the variable-speed drivers or check for speed governor or over-speed trip settings while the variable-speed driver is coupled to the pump. If the settings have not been verified, then uncouple the unit and refer to instructions supplied by the driver manufacturer.

5.1.1 Check the rotation



WARNING:

- Operating the pump in reverse rotation can result in the contact of metal parts, heat generation, and breach of containment.
 - Always disconnect and lock out power to the driver before you perform any installation or maintenance tasks. Failure to disconnect and lock out driver power will result in serious physical injury.
-

1. Unlock power to the driver.
2. Make sure that everyone is clear, and then jog the driver long enough to determine that the direction of rotation corresponds to the arrow on the pump.
3. Lock out power to the driver.

5.2 Prime the pump



CAUTION:

Do not run the pump dry.

Make sure that the pump body is full of liquid before startup. If the system does not automatically fill the pump body with liquid, then you must manually prime the pump.

1. Loosen the vent plugs on the pump body.
2. While venting the air from the pump body, rotate the pump shaft a few times by hand.
3. After all air has been purged from the pump, close the vent plugs.

5.3 Start the pump



CAUTION:

- Observe the pump for vibration levels, bearing temperature, and excessive noise. If normal levels are exceeded, shut down the pump and resolve the issue.
-

If your Series e-82SC pump is equipped with the optional ITSC or IT drive, refer to the ITSC/IT instruction manual for proper setup and running requirements.

Before you start the pump, you must perform these tasks:

- Open the suction valve.
 - Open any recirculation or cooling lines.
1. Fully close or partially open the discharge valve, depending on system conditions.
 2. Start the driver.
 3. Slowly open the discharge valve until the pump reaches the desired flow.
 4. Immediately check the pressure gauge to ensure that the pump quickly reaches the correct discharge pressure.
 5. If the pump fails to reach the correct pressure, perform these steps:
 - a) Stop the driver.
 - b) Prime the pump again.
 - c) Restart the driver.
 6. Monitor the pump while it is operating:
 - a) Check the pump for bearing temperature, excessive vibration, and noise.
 - b) If the pump exceeds normal levels, then shut down the pump immediately and correct the problem.
 7. Repeat steps 5 and 6 until the pump runs properly.

5.4 Pump operation precautions

General considerations



CAUTION:

- Vary the capacity with the regulating valve in the discharge line. Never throttle the flow from the suction side since this can result in decreased performance, unexpected heat generation, and equipment damage.
- Do not overload the driver. Driver overload can result in unexpected heat generation and equipment damage. The driver can overload in these circumstances:
 - The specific gravity of the pumped fluid is greater than expected.
 - The pumped fluid exceeds the rated flow rate.
- Make sure to operate the pump at or near the rated conditions. Failure to do so can result in pump damage from cavitation or recirculation.

Operation at reduced capacity



WARNING:

Never operate any pumping system with a blocked suction and discharge. Operation, even for a brief period under these conditions, can cause confined pumped fluid to overheat, which results in a violent explosion. You must take all necessary measures to avoid this condition.



CAUTION:

Avoid excessive vibration levels. Excessive vibration levels can damage the bearings, stuffing box or seal chamber, and the mechanical seal, which can result in decreased performance.

NOTICE:

- Avoid increased radial load. Failure to do so can cause stress on the shaft and bearings.
- Avoid heat build-up. Failure to do so can cause rotating parts to score or seize.
- Avoid cavitation. Failure to do so can cause damage to the internal surfaces of the pump.

Operation under freezing conditions

NOTICE:

Do not expose an idle pump to freezing conditions. Drain all liquid that is inside the pump and the flush lines. Failure to do so can cause liquid to freeze and damage the pump.

5.5 Shut down the pump

1. Slowly close the discharge valve.
2. Shut down and lock the driver to prevent accidental rotation.

5.6 Vibration

After startup, vibration can be measured on the pump bracket at the base of the horizontal (H), vertical (V), and axial (A) directions. The maximum expected value is 0.15 in/sec (3.8 mm/sec) RMS (ANSI/HI 9.6.4) when operating in the Preferred Operating Range (POR) flows from 70% to 120% of the best efficiency point (BEP) (ANSI/HI 9.6.3). Operation outside the POR, but within the Allowable Operating Range (AOR) from minimum flow to 85% of the end of the curve increases the vibration value by 30%. If the vibration recorded exceeds these values, shut down the pump, diagnose and fix the problem, re-start, and re-check the vibration.

6 Maintenance

6.1 Standby operation

The pump unit in use and the one on standby must alternate regularly to ensure even distribution of the hours of operation. Make the change manually or install an automatic controller.

When pumping domestic hot water, the pump units should alternate at least once per day to prevent any deposits from clogging the pump unit on standby.

6.2 Flapper valve

| | |
|--------------------|--|
| Yearly maintenance | Test the operation of the flapper valve by running the motors one at a time and checking that the motor that is not in operation turns in the correct direction. |
|--------------------|--|

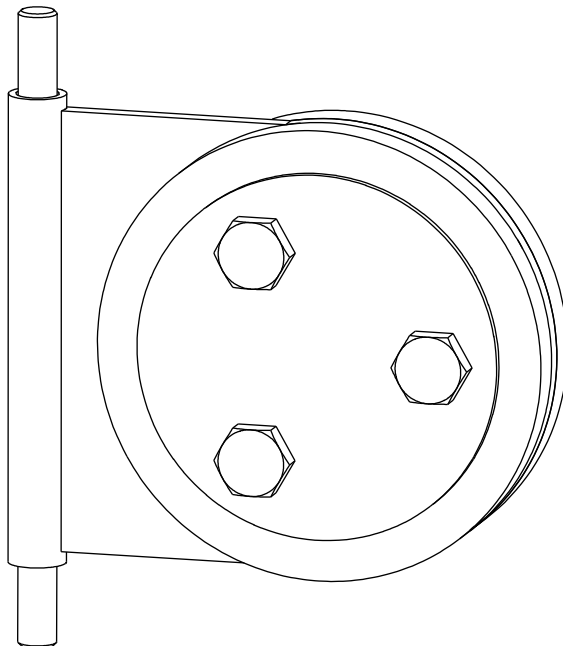

Table 1: Replacement parts

| Item | Pump Discharge Size | | | |
|----------------------|---------------------|----------|----------|----------|
| | 2.5" | 3" | 4" | 6" |
| | Part number | | | |
| Flapper kit with pin | P2005003 | P2005004 | P2005008 | P2005006 |
| Pin only | P2004848 | P2004908 | P2004913 | P2004918 |

6.3 Lubrication

The pump motor has been lubricated at the factory. Keep the motor properly lubricated in accordance with the motor manufacturer's instructions.

6.4 Disassembly

For use of Blind flange, see [Blind flange use](#) on page 26.

6.4.1 Disassembly precautions

This manual clearly identifies accepted methods for disassembling units. These methods must be adhered to.



WARNING:

- Make sure that the pump is isolated from the system and that pressure is relieved before you disassemble the pump, remove plugs, open vent or drain valves, or disconnect the piping.
 - Always disconnect and lock out power to the driver before you perform any installation or maintenance tasks. Failure to disconnect and lock out driver power will result in serious physical injury.
 - Crush hazard. The unit and the components can be heavy. Use proper lifting methods and wear steel-toed shoes at all times.
-

NOTICE:

Make sure that all replacement parts are available before you disassemble the pump for overhaul.

6.4.2 Drain the pump



CAUTION:

- Allow all system and pump components to cool before you handle them to prevent physical injury.
-

1. Close the isolation valves on the suction and discharge sides of the pump.
You must drain the system if no valves are installed.
2. Open the drain valve.
Do not proceed until liquid stops coming out of the drain valve. If liquid continues to flow from the drain valve, the isolation valves are not sealing properly and you must repair them before you proceed.
3. Leave the drain valve open and remove the drain plug located on the bottom of the pump housing and suction passage.
Do not reinstall the plug or close the drain valve until the reassembly is complete.
4. Drain the liquid from the piping and flush the pump if it is necessary.
5. Disconnect all auxiliary piping and tubing.

6.4.3 Impeller trimming guidelines

Machining

When it is necessary to reduce the pump flow rate and generated head by trimming the impeller diameter, the following guidelines apply for stainless steel impellers:

- Review the pump hydraulic selection data and consult your local Xylem representative to select the proper reduced diameter.
- For machining recommendations, see P2002535 Stainless Steel Impeller Trimming Guidelines.

Balancing

It is recommended that impellers trimmed more than 5% in diameter be rebalanced per ISO 1940 grade G6.3.

6.5 Pre-assembly inspections

Guidelines

Before you assemble the pump parts, make sure you follow these guidelines:

- Inspect the pump parts according to the information in these pre-assembly topics before you reassemble your pump. Replace any part that does not meet the required criteria.
- Make sure that the parts are clean. Clean the pump parts in solvent in order to remove oil, grease, and dirt.

NOTICE:

Protect machined surfaces while you clean the parts. Failure to do so may result in equipment damage.

6.5.1 Replacement guidelines

Impeller replacement

This table shows the criteria for replacing the impeller:

| Impeller parts | When to replace |
|----------------|--|
| Impeller vanes | <ul style="list-style-type: none"> • When grooved deeper than 1/16 in. (1.6 mm), or • When worn evenly more than 1/32 in. (0.8 mm) |
| Vane edges | When you see cracks, pitting, or corrosion damage |

Gaskets, O-rings, and seats replacement

- Replace all gaskets and O-rings at each overhaul and disassembly.
- Inspect the seats. They must be smooth and free of physical defects.
- Replace flapper valve if found damaged, worn or faulty. Flapper valve must be replaced as a complete kit with pin. Flapper valve pin only available for replacement in case of loss or damage.

6.5.2 Shaft inspection

Inspection criteria

Inspect the shaft according to this criteria:

- Thoroughly clean the shaft .
- Thoroughly clean the coverplate seal cavity.
- Inspect the surface for damage such as pitting, corrosion, nicks, and scratches.

Replace these parts if they are damaged.

6.6 Reassembly

6.6.1 Replace the seal

The inside and outside seal can be replaced without removing the motor.

1. Remove the coupling guard.
2. Remove the flush line from the seal cap.
3. If an outside seal, put seal clips in the seal and then loosen the set screws that hold the seal on the shaft.
4. Remove the coupler halves. Tape the collar rings together in pairs as assembled previously.
The shaft drops down when the coupling is removed.
5. If an outside seal, remove the seal.
6. Remove the seal cap or seal gland through the space between shafts.
 - a) Remove the seal seat from the seal cap or gland.
 - b) If an inside seal, remove the seal using a pair of screwdrivers, to pry out the seal.
7. Clean the seal box, seal cap, or gland and shaft.

**CAUTION:**

Avoid touching the carbon face and ceramic face of the seal and getting it dirty.

8. Place the seal seat in the seal cap or gland.
9. For an outside seal:
 - a) Install the seal seat with seal cap or gland (including the gaskets on either side of the seat) over the end of the shaft and fasten to the motor bracket with four cap screws and washers. Tighten seal gland cap screws evenly to avoid misalignment one quarter turn past hand tight.
 - b) Leave the seal holding clips on the rotating part of the seal, lubricate the bore of the seal with soapy water or other suitable lubricant such as International Products Corporation P-80®, and install the rotating part of the seal on the shaft with the rotating face toward the seal seat.
 - c) After the coupling assembly (see below), tighten the seal set screws on the shaft and remove the seal holding clips. The seal is now set. Keep the seal holding clips in case the seal has to be removed in the future.

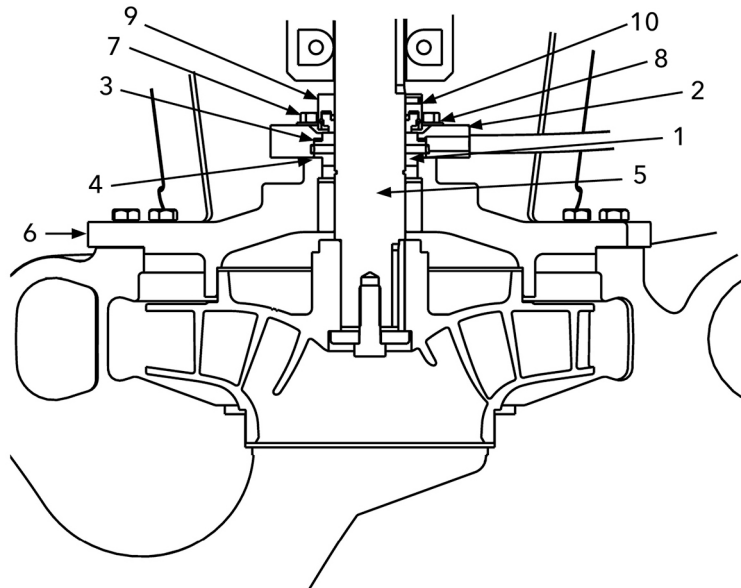

Figure 11: Outside seal

1. Seal seat
 2. Seal cap or gland
 3. Seal seat gasket (seat to cap or gland)
 4. Seal seat gasket (seat to motor bracket)
 5. Shaft
 6. Motor bracket
 7. Seal gland cap screws
 8. Washers
 9. Rotating part of the seal
 10. Seal set screws
10. For an inside seal:
 - a) Lubricate the bore of the rotating part of the seal with soapy water or other suitable lubricant such as International Products Corporation P-80®, and install the seal on the shaft with the rotating face up toward the motor until it contacts the snap ring.
 - b) Install the seal seat with seal cap or gland (with the gasket between the cap and the motor bracket) over the end of the shaft and affix to the motor bracket with four cap

screws and washers. Tighten seal gland cap screws evenly to avoid misalignment one quarter turn past hand tight.

- c) The seal is now fully installed and will be set after coupling assembly.

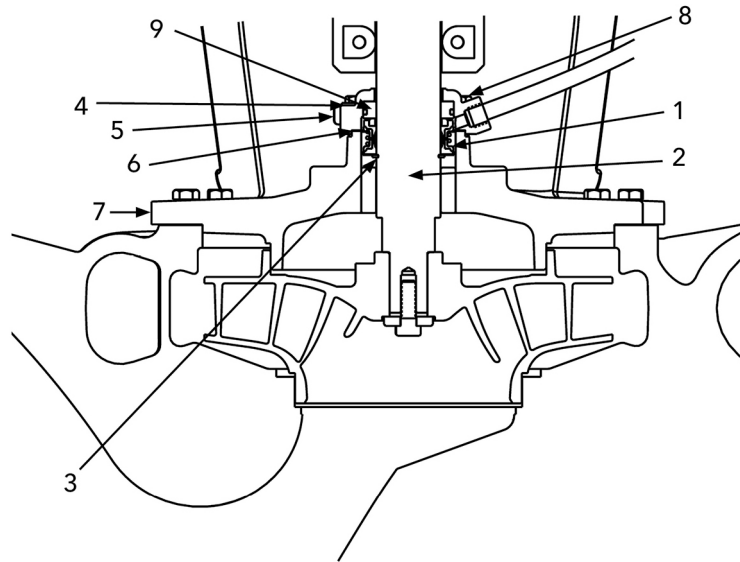

Figure 12: Inside seal

1. Rotating part of the seal
2. Shaft
3. Snap ring
4. Seal seat
5. Seal cap or gland
6. Seal cap gasket
7. Motor bracket
8. Seal gland cap screws
9. Washers

11. Reinstall the flush line.

12. Reinstall the coupling guard.

6.6.2 Motor collar ring setting



CAUTION:

The motor collar ring must be set on the motor shaft at the correct position and set screws torqued to the proper value.

The motor collar ring must be set on the motor shaft at a specified distance to insure the pump impeller is in the proper position during pump operation. The distance to set the collar (DC) is measured from the motor mounting surface to the surface of the collar ring closest to the motor.

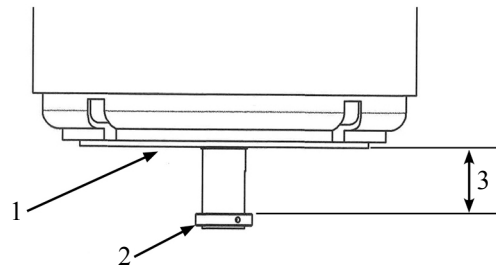

Figure 13: Motor collar ring setting for TC motor except 143-145TC motor

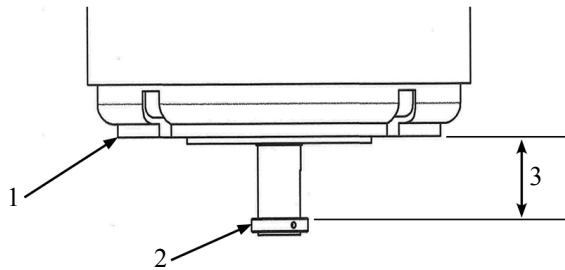

Figure 14: Motor collar ring setting for 143-145TC motor

1. Motor mounting surface
2. Collar ring
3. DC

The collar ring is held in position on the motor shaft with set screws. These set screws must be tightened to the proper torque to ensure that the collar does not slip as a result of pump rotor weight and pump hydraulic thrust.

Place a small amount of Loctite 222MS on each setscrew before installing them into the motor collar.

Table 2: Collar setting distance

This table describes the collar setting distance, set screw size, and set screw torque for TC motors.

| Motor frame size | Distance Collar (DC) in (mm) | Set screw size | Set screw torque in-lbs |
|------------------|------------------------------|----------------|-------------------------|
| 182TC – 184TC | 2.121 (53.87) | #8-32UNC | 20 |
| 213TC – 215TC | 2.597 (65.96) | #10-32UNF | 36 |
| 254TC – 256TC | 3.227 (81.97) | #10-32UNF | 36 |
| 284TC – 286TC | 3.735 (94.87) | .25-28UNF | 87 |
| 324TSC – 365TSC | 2.855 (72.52) | .25-28UNF | 87 |
| 324TC-326TC | 4.375 (111.13) | .25-28UNF | 87 |
| 364TC-365TC | 4.875 (123.83) | .313-24UNF | 165 |

6.6.3 Assemble the coupler

1. Ensure the coupler halves are clean and burr free. Use sand paper to remove any burrs and sharp edges with the keyways, set screw collar groove and tapered washer groove. The collar, tapered washer and keys must slide within their grooves without interference.
2. If removed, install the set screw collar ring on the motor shaft according to the instructions in [Motor collar ring setting](#) on page 23.

3. Upon disassembly, the impeller and pump shaft weight cause the rotor to move downward and rest at the bottom of the volute. During reassembly, pump shaft and impeller will be pulled back up into position by the tapered washer acting against the tapered groove in the coupler.
4. After the seal is pre-assembled onto the pump according the section above, assemble the tapered washer with cap screw and lock washer on the end of the pump shaft. An allen wrench can be placed in the hole on the side of the shaft to prevent it from rotating while tightening the cap screw.
5. Install the keys in the motor and pump shafts and turn the motor shaft until the keys line up.
6. Place the coupler half with the key ways on the motor setscrew collar and on both keys. Check that the tapered washer installed on the end of the pump shaft is starting to engage the taper groove in the coupler half.
7. Place the other half of the coupler around the shaft.

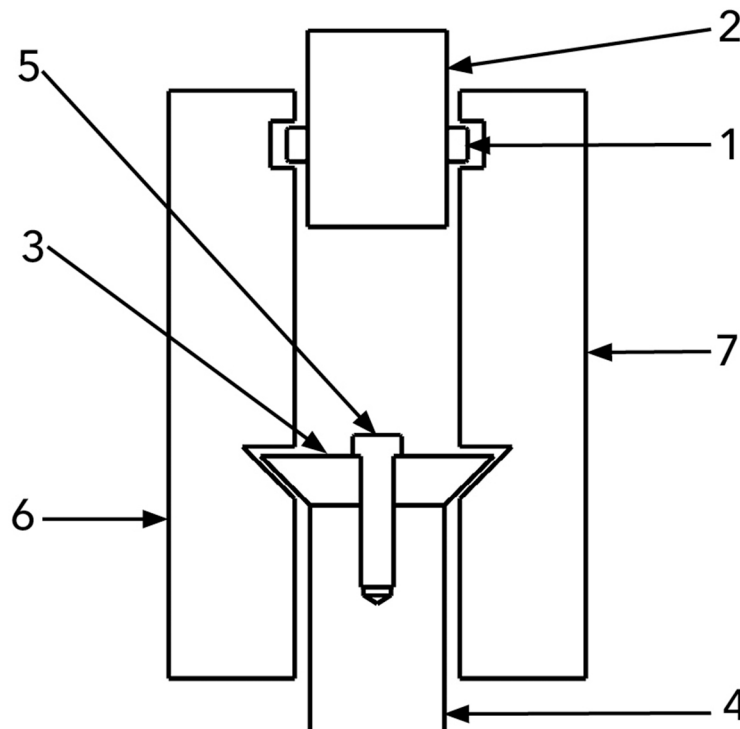

Figure 15: Coupler

1. Set screw collar ring
2. Motor shaft
3. Tapered washer
4. Pump shaft with attached impeller (not shown)
5. Taper washer cap screw and lock washer
6. Coupler half
7. Coupler half
8. Insert the coupler cap screws and place a lock washer and nut on each screw. The bolt heads at each level on opposite sides of the coupling should face in different directions for balance as shown in [Figure 16: Top view](#) on page 26.
9. Tighten all of the bolts evenly to avoid mis-alignment. The shaft and impeller are pulled up in to position as the bolts are tightened. Then rotate the shaft by hand and make sure the gap on both sides of the coupler is approximately equal. Make sure the gap from the top to the bottom of the coupler is even. If the gap is not equal, loosen the bolts and repeat the tightening step.
10. Slowly rotate the shaft by hand and check to see if any rubs occur.

1. If no rubs occur, prime and start the pump run for two minutes and determine if the pump run smooth and vibration free.
2. If problems occur, check the installation and repeat as necessary.

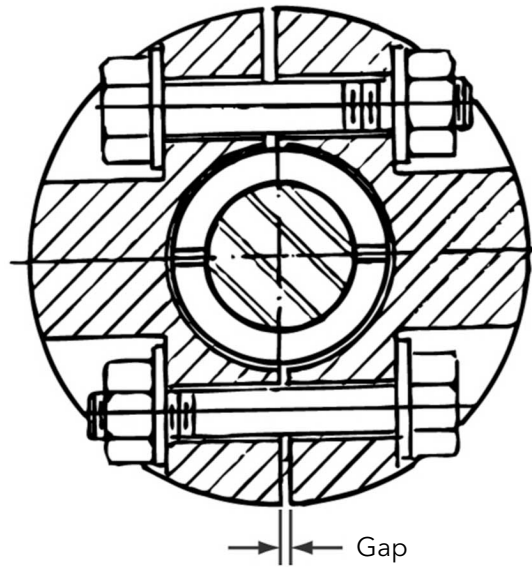

Figure 16: Top view

6.6.4 Assemble the flapper valve

1. Tighten self-sealing bolt on non-drive end of volute.
2. Align and hold flapper valve body with volute holes and insert pin from drive end side so that it goes through valve body bore.
3. Tighten self-sealing bolt on drive end side of volute.
4. Flapper valve should be able to swivel freely after assembly.

6.6.5 Blind flange use

To perform maintenance on one pump unit while the other unit is running, place a blind flange on the pump base.

Make sure that the pump is isolated from the system and that pressure is relieved before you disassemble the pump and install blind flange.

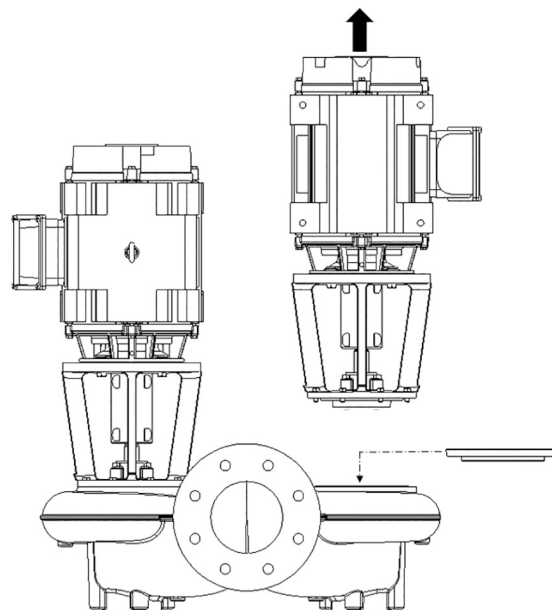

| | | | |
|--------------------------|----------|----------|----------|
| Impeller size | 7" | 9.5" | 11" |
| Blind flange part number | P2004870 | P2004741 | P2004743 |

6.6.5.1 Install the blind flange



1. Shut down the pump. See [Shut down the pump](#) on page 18.
2. Drain the pump. See [Drain the pump](#) on page 20.
3. Remove the pump assembly in need of maintenance. See [Remove the pump assembly](#). Use proper lifting guidelines.
4. Install the blind flange using volute capscrews from the removed pump assembly. Tighten the volute capscrews according to [Screw torque values](#) on page 27. Always install a new volute gasket with the blind flange.
5. After the blind flange is installed the pump is ready to be primed and started. See [Prime the pump](#) on page 17 and [Start the pump](#) on page 17.

6.6.5.2 Remove the blind flange

1. Shut down the pump. See [Shut down the pump](#) on page 18.
2. Drain the pump. See [Drain the pump](#) on page 20.
3. Remove the blind flange. Dispose of the used gasket. Save the capscrews for pump assembly reinstallation.
4. Reinstall the pump assembly. See [Reinstall the pump assembly](#).

6.6.6 Screw torque values

Capscrew torque in ft-lb (Nm)

| Capscrew type | Head marking | Capscrew diameter (in inches) | | | | | | | | |
|---------------------------|---|-------------------------------|---------|---------|---------|----------|-----------|-----------|-----------|------------|
| | | 1/4 | 5/16 | 3/8 | 7/16 | 1/2 | 5/8 | 3/4 | 7/8 | 1 |
| SAE grade 2 |  | 6 (8) | 13 (18) | 25 (34) | 38 (52) | 60 (81) | 120 (163) | 190 (258) | 210 (285) | 300 (407) |
| Brass and stainless steel | or  | 4 (5) | 10 (14) | 17 (23) | 27 (37) | 42 (57) | 83 (113) | 130 (176) | 200 (271) | 300 (407) |
| SAE grade 5 |  | 10 (14) | 20 (27) | 35 (47) | 60 (81) | 90 (122) | 180 (244) | 325 (440) | 525 (712) | 800 (1085) |

6.6.7 Dealer servicing

If trouble occurs that cannot be rectified, contact your local sales and service representative and be prepared to provide this information:

1. Complete nameplate data of pump and motor
2. Suction and discharge pipe pressure gauge readings
3. Ampere draw of the motor
4. A sketch of the pump hook-up and piping

7 Troubleshooting

7.1 Precautions

WARNING:

Maintenance and service must be performed by skilled and qualified personnel only.

7.2 The pump unit is turned on but does not work

| Cause | Remedy |
|--|--|
| Power supply cut off | Restore the power supply |
| The thermal overload protection of the motor has been triggered | Reset the thermal overload protection in the control panel or the one in the pump unit |
| The device that detects the absence of liquid or minimum pressure has been triggered | Top up the liquid or restore minimum pressure |
| Power supply cable is damaged | Replace the power supply cable |
| The condenser is faulty, if present | Replace the condenser |
| Control panel is faulty | Check and repair or replace the control panel |
| Motor (coil) faulty | Check and repair or replace the motor |

7.3 The differential protection device (RCD) is activated

| Cause | Remedy |
|---------------------------------|---------------------------------------|
| Motor leaking | Check and repair or replace the motor |
| Unsuitable type of differential | Check the type of differential |

7.4 The thermal overload protection of the motor is triggered when the pump unit starts

| Cause | Remedy |
|---|--|
| It is calibrated at a value too low in relation to the rated current of the motor | Recalibrate |
| Missing power supply phase | Check the power supply and restore the phase |
| Loose and/or faulty connections of the thermal overload protection | Tighten or replace the clamps and terminals |
| Loose and/or incorrect and/or fault (star-delta) connections in the terminal board of the motor | Tighten or replace the clamps and terminals |
| Motor (coil) faulty | Check and repair or replace the motor |
| Pump unit mechanically seized up | Check and repair the pump unit |
| Power supply cable is damaged | Replace the power supply cable |
| Check valve faulty | Replace the check valve |
| Foot check valve faulty | Replace the foot check valve |
| Flapper valve damaged, worn or faulty | Replace the flapper valve |

7.5 The thermal overload protection of the motor is triggered occasionally, or after the pump unit has been running for a few minutes

| Cause | Remedy |
|---|--|
| It is calibrated at a value too low in relation to the rated current of the motor | Recalibrate |
| Input voltage outside the rated limits | Make sure the voltage values are correct |
| Unbalanced input voltage | Make sure the voltage of the three phases is balanced |
| Incorrect working curve (flow rate greater than the maximum permitted flow rate) | Reduce the required flow rate |
| Liquid too dense, presence of solid or fibrous substances (pump unit overloaded) | <ul style="list-style-type: none"> • Reduce the density of the liquid and/or • Remove the solid substance and/or • Increase the size of the motor |
| Room temperature too high, exposure to sunlight | <ul style="list-style-type: none"> • Lower the temperature at the point of the thermal overload protection and/or • Protect against direct sunlight |
| Pump unit faulty | Send the pump unit to an authorized workshop for testing |

7.6 The pump unit runs but delivers too little or no liquid

| Cause | Remedy |
|---|--|
| Motor turns in the wrong direction | Check the direction of rotation and change it if necessary |
| Incorrect priming (there are air bubbles in the suction pipe or in the pump unit) | Repeat the priming procedure |
| Cavitation | Increase the NPSH available in the system |
| Check valve locked in closed or partially closed position | Replace the check valve |
| Foot check valve locked in closed or partially closed position | Replace the foot valve |
| Flapper valve damaged, worn, or faulty | Replace the flapper valve |
| Delivery pipe throttled | Remove the throttling |
| Piping and/or pump unit clogged | Remove the clogging |

7.7 The pump unit turns the other way when turned off

| Cause | Remedy |
|--|---------------------------|
| Check valve faulty | Replace the check valve |
| Foot check valve faulty | Replace the foot valve |
| Flapper valve damaged, worn, or faulty | Replace the flapper valve |

7.8 The pump unit produces excessive noise and/or vibrations

| Cause | Remedy |
|-------------------------------------|---|
| Cavitation | Increase the NPSH available in the system |
| Unsuitable anchoring to the ground | Check the anchoring to the ground |
| Resonance | Check the installation |
| Anti-vibration joints not installed | Install anti-vibration joints on the suction and discharge lines of the pump unit |
| Foreign bodies in the pump unit | Remove the foreign bodies |

| Cause | Remedy |
|--|--|
| Motor bearings worn or faulty | Replace the motor bearings |
| The pump unit does not turn freely due to a mechanical fault | Send the pump unit to an authorized workshop for testing |
| Flapper valve damaged, worn, or faulty | Replace flapper valve |
| Motor turns in the wrong direction | Check the direction of rotation and change it if necessary |

7.9 The pump starts up too frequently (automatic start/stop)

| Cause | Remedy |
|---|--|
| Incorrect priming (there are air bubbles in the suction pipe or in the pump units) | Repeat the priming procedure |
| Check valve locked in closed or partially closed position | Replace the check valve |
| Foot check valve locked in closed or partially closed position | Replace the foot valve |
| Flapper valve damaged, worn or faulty | Replace the flapper valve |
| Starter (pressure switch, sensor, etc.) set incorrectly, or faulty | Adjust or replace the starter |
| Expansion vessel <ul style="list-style-type: none"> • No pre-charge, or • Undersized, or • Not installed | <ul style="list-style-type: none"> • Pre-charge the expansion vessel, or • Replace the expansion vessel with another suitable one, or • Install an expansion vessel |
| Pump unit oversized | Contact Xylem or the Authorized Distributor |

7.10 The pump unit never stops (automatic start/stop)

| Cause | Remedy |
|--|---|
| The required flow rate is greater than the one expected | Reduce the required flow rate |
| Delivery pipe leaking | Eliminate the leaks |
| Motor turns in the wrong direction | Check the direction of rotation and change it if necessary |
| Pipes, valves or filter clogged with impurities | Remove the impurities |
| Starter (pressure switch, sensor, etc.) set incorrectly, or faulty | Adjust or replace the starter |
| The pump unit runs but delivers too little or no liquid | See "The pump unit runs but delivers too little or no liquid" |

7.11 The mechanical seal is leaking

| Cause | Remedy |
|---|---|
| Worn mechanical seal | <ul style="list-style-type: none"> • Replace the mechanical seal, or • Fit a mechanical seal with harder contact surfaces |
| Mechanical seal damaged due to thermal shock (presence of air bubbles in pump unit) | Replace the mechanical seal |
| Defective mechanical seal | Replace the mechanical seal |
| Mechanical seal damaged due to temperature of the liquid outside the rated limits | Replace the mechanical seal with another of a suitable make |
| Mechanical seal damaged due to chemical incompatibility with the liquid | Replace the mechanical seal with one of a make chemically compatible with the pumped liquid |

7.12 The motor becomes excessively hot

| Cause | Remedy |
|---|------------------------------------|
| Room temperature outside the rated limits | Lower the room temperature |
| Cooling fan of the motor clogged or damaged | Clean or replace the cooling fan |
| The pump unit starts up too frequently | See Part 7.8 |
| The frequency converter, if present, has not been calibrated properly | See the frequency converter manual |

7.13 The frequency converter (if present) is in error mode or turned off

| Cause | Remedy |
|------------------------------------|------------------------------------|
| See the frequency converter manual | See the frequency converter manual |

8 Product Warranty

Commercial warranty

Warranty. For goods sold to commercial buyers, Seller warrants the goods sold to Buyer hereunder (with the exception of membranes, seals, gaskets, elastomer materials, coatings and other "wear parts" or consumables all of which are not warranted except as otherwise provided in the quotation or sales form) will be (i) be built in accordance with the specifications referred to in the quotation or sales form, if such specifications are expressly made a part of this Agreement, and (ii) free from defects in material and workmanship for a period of one (1) year from the date of installation or eighteen (18) months from the date of shipment (which date of shipment shall not be greater than thirty (30) days after receipt of notice that the goods are ready to ship), whichever shall occur first, unless a longer period is specified in the product documentation (the "Warranty").

Except as otherwise required by law, Seller shall, at its option and at no cost to Buyer, either repair or replace any product which fails to conform with the Warranty provided Buyer gives written notice to Seller of any defects in material or workmanship within ten (10) days of the date when any defects or non-conformance are first manifest. Under either repair or replacement option, Seller shall not be obligated to remove or pay for the removal of the defective product or install or pay for the installation of the replaced or repaired product and Buyer shall be responsible for all other costs, including, but not limited to, service costs, shipping fees and expenses. Seller shall have sole discretion as to the method or means of repair or replacement. Buyer's failure to comply with Seller's repair or replacement directions shall terminate Seller's obligations under this Warranty and render the Warranty void. Any parts repaired or replaced under the Warranty are warranted only for the balance of the warranty period on the parts that were repaired or replaced. Seller shall have no warranty obligations to Buyer with respect to any product or parts of a product that have been: (a) repaired by third parties other than Seller or without Seller's written approval; (b) subject to misuse, misapplication, neglect, alteration, accident, or physical damage; (c) used in a manner contrary to Seller's instructions for installation, operation and maintenance; (d) damaged from ordinary wear and tear, corrosion, or chemical attack; (e) damaged due to abnormal conditions, vibration, failure to properly prime, or operation without flow; (f) damaged due to a defective power supply or improper electrical protection; or (g) damaged resulting from the use of accessory equipment not sold or approved by Seller. In any case of products not manufactured by Seller, there is no warranty from Seller; however, Seller will extend to Buyer any warranty received from Seller's supplier of such products.

THE FOREGOING WARRANTY IS EXCLUSIVE AND IN LIEU OF ANY AND ALL OTHER EXPRESS OR IMPLIED WARRANTIES, GUARANTEES, CONDITIONS OR TERMS OF WHATEVER NATURE RELATING TO THE GOODS PROVIDED HEREUNDER, INCLUDING WITHOUT LIMITATION ANY IMPLIED WARRANTIES OF MERCHANTABILITY AND FITNESS FOR A PARTICULAR PURPOSE, WHICH ARE HEREBY EXPRESSLY DISCLAIMED AND EXCLUDED. EXCEPT AS OTHERWISE REQUIRED BY LAW, BUYER'S EXCLUSIVE REMEDY AND SELLER'S AGGREGATE LIABILITY FOR BREACH OF ANY OF THE FOREGOING WARRANTIES ARE LIMITED TO REPAIRING OR REPLACING THE PRODUCT AND SHALL IN ALL CASES BE LIMITED TO THE AMOUNT PAID BY THE BUYER FOR THE DEFECTIVE PRODUCT. IN NO EVENT SHALL SELLER BE LIABLE FOR ANY OTHER FORM OF DAMAGES, WHETHER DIRECT, INDIRECT, LIQUIDATED, INCIDENTAL, CONSEQUENTIAL, PUNITIVE, EXEMPLARY OR SPECIAL DAMAGES, INCLUDING BUT NOT LIMITED TO LOSS OF PROFIT, LOSS OF ANTICIPATED SAVINGS OR REVENUE, LOSS OF INCOME, LOSS OF BUSINESS, LOSS OF PRODUCTION, LOSS OF OPPORTUNITY OR LOSS OF REPUTATION.

Limited consumer warranty

Warranty. For goods sold for personal, family or household purposes, Seller warrants the goods purchased hereunder (with the exception of membranes, seals, gaskets, elastomer

materials, coatings and other "wear parts" or consumables all of which are not warranted except as otherwise provided in the quotation or sales form) will be free from defects in material and workmanship for a period of one (1) year from the date of installation or eighteen (18) months from the product date code, whichever shall occur first, unless a longer period is provided by law or is specified in the product documentation (the "Warranty").

Except as otherwise required by law, Seller shall, at its option and at no cost to Buyer, either repair or replace any product which fails to conform with the Warranty provided Buyer gives written notice to Seller of any defects in material or workmanship within ten (10) days of the date when any defects or non-conformance are first manifest. Under either repair or replacement option, Seller shall not be obligated to remove or pay for the removal of the defective product or install or pay for the installation of the replaced or repaired product and Buyer shall be responsible for all other costs, including, but not limited to, service costs, shipping fees and expenses. Seller shall have sole discretion as to the method or means of repair or replacement. Buyer's failure to comply with Seller's repair or replacement directions shall terminate Seller's obligations under this Warranty and render this Warranty void. Any parts repaired or replaced under the Warranty are warranted only for the balance of the warranty period on the parts that were repaired or replaced. The Warranty is conditioned on Buyer giving written notice to Seller of any defects in material or workmanship of warranted goods within ten (10) days of the date when any defects are first manifest.

Seller shall have no warranty obligations to Buyer with respect to any product or parts of a product that have been: (a) repaired by third parties other than Seller or without Seller's written approval; (b) subject to misuse, misapplication, neglect, alteration, accident, or physical damage; (c) used in a manner contrary to Seller's instructions for installation, operation and maintenance; (d) damaged from ordinary wear and tear, corrosion, or chemical attack; (e) damaged due to abnormal conditions, vibration, failure to properly prime, or operation without flow; (f) damaged due to a defective power supply or improper electrical protection; or (g) damaged resulting from the use of accessory equipment not sold or approved by Seller. In any case of products not manufactured by Seller, there is no warranty from Seller; however, Seller will extend to Buyer any warranty received from Seller's supplier of such products.

THE FOREGOING WARRANTY IS PROVIDED IN PLACE OF ALL OTHER EXPRESS WARRANTIES. ALL IMPLIED WARRANTIES, INCLUDING BUT NOT LIMITED TO THE IMPLIED WARRANTIES OF MERCHANTABILITY AND FITNESS FOR A PARTICULAR PURPOSE, ARE LIMITED TO ONE (1) YEAR FROM THE DATE OF INSTALLATION OR EIGHTEEN (18) MONTHS FROM THE PRODUCT DATE CODE, WHICHEVER SHALL OCCUR FIRST. EXCEPT AS OTHERWISE REQUIRED BY LAW, BUYER'S EXCLUSIVE REMEDY AND SELLER'S AGGREGATE LIABILITY FOR BREACH OF ANY OF THE FOREGOING WARRANTIES ARE LIMITED TO REPAIRING OR REPLACING THE PRODUCT AND SHALL IN ALL CASES BE LIMITED TO THE AMOUNT PAID BY THE BUYER FOR THE DEFECTIVE PRODUCT. IN NO EVENT SHALL SELLER BE LIABLE FOR ANY OTHER FORM OF DAMAGES, WHETHER DIRECT, INDIRECT, LIQUIDATED, INCIDENTAL, CONSEQUENTIAL, PUNITIVE, EXEMPLARY OR SPECIAL DAMAGES, INCLUDING BUT NOT LIMITED TO LOSS OF PROFIT, LOSS OF ANTICIPATED SAVINGS OR REVENUE, LOSS OF INCOME, LOSS OF BUSINESS, LOSS OF PRODUCTION, LOSS OF OPPORTUNITY OR LOSS OF REPUTATION.

Some states do not allow limitations on how long an implied warranty lasts, so the above limitation may not apply to you. Some states do not allow the exclusion or limitation of incidental or consequential damages, so the above exclusions may not apply to you. This warranty gives you specific legal rights, and you may also have other rights which may vary from state to state.

To make a warranty claim, check first with the dealer from whom you purchased the product or visit www.xyleminc.com for the name and location of the nearest dealer providing warranty service.

Xylem |'zīləm|

- 1) The tissue in plants that brings water upward from the roots;
- 2) a leading global water technology company.

We're a global team unified in a common purpose: creating advanced technology solutions to the world's water challenges. Developing new technologies that will improve the way water is used, conserved, and re-used in the future is central to our work. Our products and services move, treat, analyze, monitor and return water to the environment, in public utility, industrial, residential and commercial building services settings. Xylem also provides a leading portfolio of smart metering, network technologies and advanced analytics solutions for water, electric and gas utilities. In more than 150 countries, we have strong, long-standing relationships with customers who know us for our powerful combination of leading product brands and applications expertise with a strong focus on developing comprehensive, sustainable solutions.

For more information on how Xylem can help you, go to www.xylem.com



Xylem Inc.
8200 N. Austin Avenue
Morton Grove IL 60053
Tel: (847) 966-3700
Fax: (847) 965-8379
www.xylem.com/bellgossett

Visit our Web site for the latest version of this document and more information

The original instruction is in English. All non-English instructions are translations of the original instruction.

© 2020 Xylem Inc

Bell & Gossett is a trademark of Xylem Inc or one of its subsidiaries.